



GO CHAIR

Safety Guidelines



WARNING! An authorized Pride Provider or a qualified technician must perform the initial setup of this travel chair and must perform all of the procedures in this manual.

The symbols below are used throughout this owner's manual and on the Go-Chair to identify warnings and important information. It is very important for you to read them and understand them completely.



WARNING! Indicates a potentially hazardous condition/situation. Failure to follow designated procedures can cause either personal injury, component damage, or malfunction. On the product, this icon is represented as a black symbol on a yellow triangle with a black border.



MANDATORY! These actions should be performed as specified. Failure to perform mandatory actions can cause personal injury and/or equipment damage. On the product, this icon is represented as a white symbol on a blue dot with a white border.



PROHIBITED! These actions are prohibited. These actions should not be performed at any time or in any circumstances. Performing a prohibited action can cause personal injury and/or equipment damage. On the product, this icon is represented as a black symbol with a red circle and red slash.

INTENDED USE

The intended use of the Pride Mobility Products device is to provide mobility to persons limited to a seated position that have the capacity of operating a powered wheelchair.

REGARDING DEVICES FOR PRESCRIPTION USE



CAUTION! Federal law restricts this device to sale by or on the order of a physician or other certified personnel licensed by the law of the State (US only) or region in which this personnel practices to use or order the use of the device.

Quick Reference Information

Authorized Pride Provider: _____

Address: _____

Telephone: _____

Purchase Date: _____

NOTE: This owner's manual is compiled from the latest specifications and product information available at the time of publication. We reserve the right to make changes as they become necessary. Any changes to our products may cause slight variations between the illustrations and explanations in this manual and the product you have purchased. The latest/current version of this manual is available on our website.

NOTE: This product is compliant with WEEE, RoHS, and REACH directives and requirements.

NOTE: This product meets IPX4 classification (IEC 60529).

NOTE: This product and its components are not made with natural rubber latex. Consult with the manufacturer regarding any after-market accessories.



Table of Contents

3

Introduction.....	4
Safety.....	5
Your Go-Chair.....	7
Assembly/Disassembly.....	10
Comfort Adjustments.....	13
Batteries and Charging.....	17
Care and Maintenance.....	23

Safety

WELCOME to Pride Mobility Products (Pride). The travel chair you have purchased combines state-of-the-art components with **safety**, comfort, and styling in mind. We are confident that these design features will provide you with the conveniences you expect during your daily activities. Once you understand how to **safely** operate and care for your travel chair, it should give you years of trouble free operation and service.

Read and **follow** all instructions, warnings, and notes in this manual before attempting to operate your travel chair for the first time. You must also read all instructions, warnings, and notes contained in any supplemental instructional booklets for the controller that accompanied your travel chair before initial operation. Your **safety** depends upon you, as well as your provider, caretaker, or healthcare professional in using good judgment.

If there is any information in this manual which you do not understand, or if you require additional assistance for setup or operation, please contact your authorized Pride Provider. **Failure to follow the instructions in this manual and those located on your travel chair can lead to personal injury and/or damage to the travel chair, including voiding the warranty.**

Purchaser's Agreement

By accepting delivery of this product, you promise that you will not change, alter, or modify this product or remove or render inoperable or unsafe any guards, shields, or other safety features of this product; fail, refuse, or neglect to install any retrofit kits from time to time provided by Pride to enhance or preserve the safe use of this product.

Shipping and Delivery

Before using your travel chair, make sure your delivery is complete as some components may be individually packaged. If you do not receive a complete delivery, please contact your authorized Pride Provider immediately. Where damage has occurred during transport, either to the packaging or content, please contact the delivery company responsible.

NOTE: If you ever lose or misplace your copy of this manual, contact us and we will be glad to send you a new one immediately.

Product safety symbols

The symbols below are used on the travel chair to identify warnings, mandatory actions, and prohibited actions. It is very important for you to read and understand them completely.

NOTE: There are more warnings identified and explained in the Consumer Safety Guide that is included with your travel chair. Please become familiar with all the warnings and safety information found in the Consumer Safety Guide.



Read and follow the information in the owner’s manual.



Locked and in drive mode.

Place unit on level ground and stand to one side when changing from drive mode to freewheel mode or freewheel mode to drive mode.

Unlocked and in freewheel mode.



Indicates travel chair securement points.

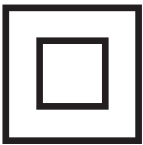

Class II Equipment.



Manufactured in.



Travel Chair information label.

General Guidelines



MANDATORY! Do not operate your new Go-Chair for the first time without completely reading and understanding this owner's manual.

Your Go-Chair is a state-of-the-art life-enhancement device designed to increase mobility. Pride provides an extensive variety of products to best fit the individual needs of the Go-Chair user. Please be aware that the final selection and purchasing decision regarding the type of travel chair to be used is the responsibility of the Go-Chair user, who is capable of making such a decision, and his/her healthcare professional (i.e., medical doctor, physical therapist, etc.).

The contents of this manual are based on the expectation that a mobility device expert has properly fitted the Go-Chair to the user and has assisted the prescribing healthcare professional and/or the authorized Pride Provider in the instruction process for the use of the product.

There are certain situations, including some medical conditions, where the Go-Chair user will need to practice operating the Go-Chair in the presence of a trained attendant. A trained attendant can be defined as a family member or care professional specially trained in assisting a Go-Chair user in various daily living activities.

As you begin using your Go-Chair during daily activities, you will probably encounter situations in which you will need some practice. Simply take your time and you will soon be in full and confident control as you maneuver through doorways, on and off of lifts, up and down ramps, and over moderate terrain.

Below are some precautions, tips, and other safety considerations that will help you become accustomed to operating your Go-Chair safely.

Pre-Ride Safety Check

Get to know the feel of your Go-Chair and its capabilities. Pride recommends that you perform a safety check before each use to make sure your Go-Chair operates smoothly and safely.

Perform the following inspections prior to using your Go-Chair:

- Check all electrical connections. Make sure they are tight and not corroded.
- Check all controller connections to the power base. Make sure they are secured properly.
- Check the brakes. See "Care and Maintenance."
- Check battery charge. See "Batteries and Charging."
- Ensure the manual freewheel levers are in drive mode before sitting on the travel chair.

NOTE: If you discover a problem, contact your authorized Pride Provider for assistance.

The Go-Chair

The Go-Chair has two main assemblies: the seat assembly and the power base assembly. **See figure 1.** Typically, the seat assembly includes the armrests, seatback, and seat base. The power base assembly includes the two motors, two drive wheels, two caster wheels, two anti-tip wheels, two batteries, and a foot platform. **See figures 1 and 2.**

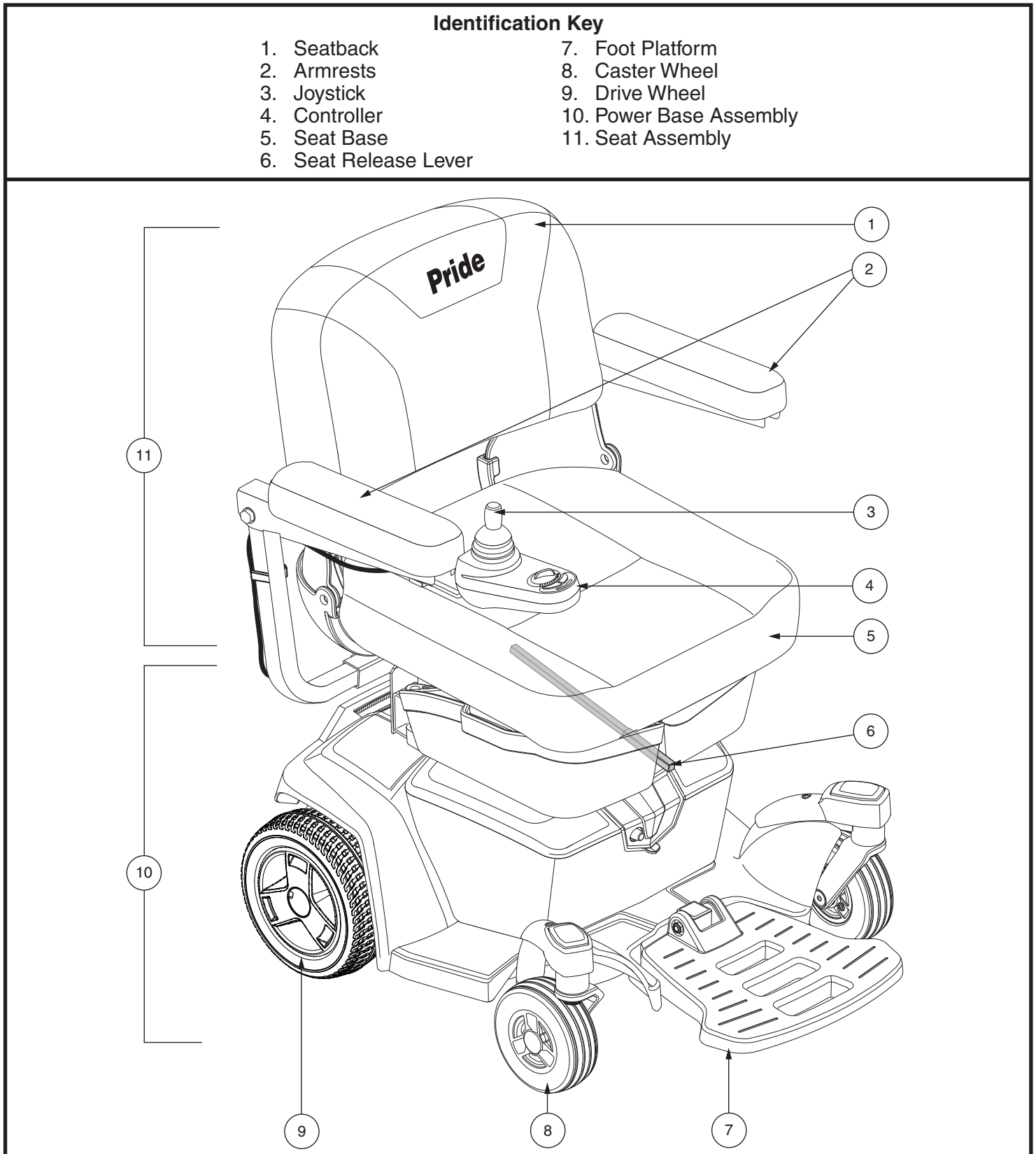

Figure 1. The Go-Chair

Identification Key

- | | |
|----------------------------------|----------------------------------|
| 1. Manual Freewheel Levers | 5. Circuit Breaker |
| 2. Seat post | 6. Front Section |
| 3. Battery Box | 7. Rear Section |
| 4. Battery Charger Port Location | 8. Controller Connector Location |

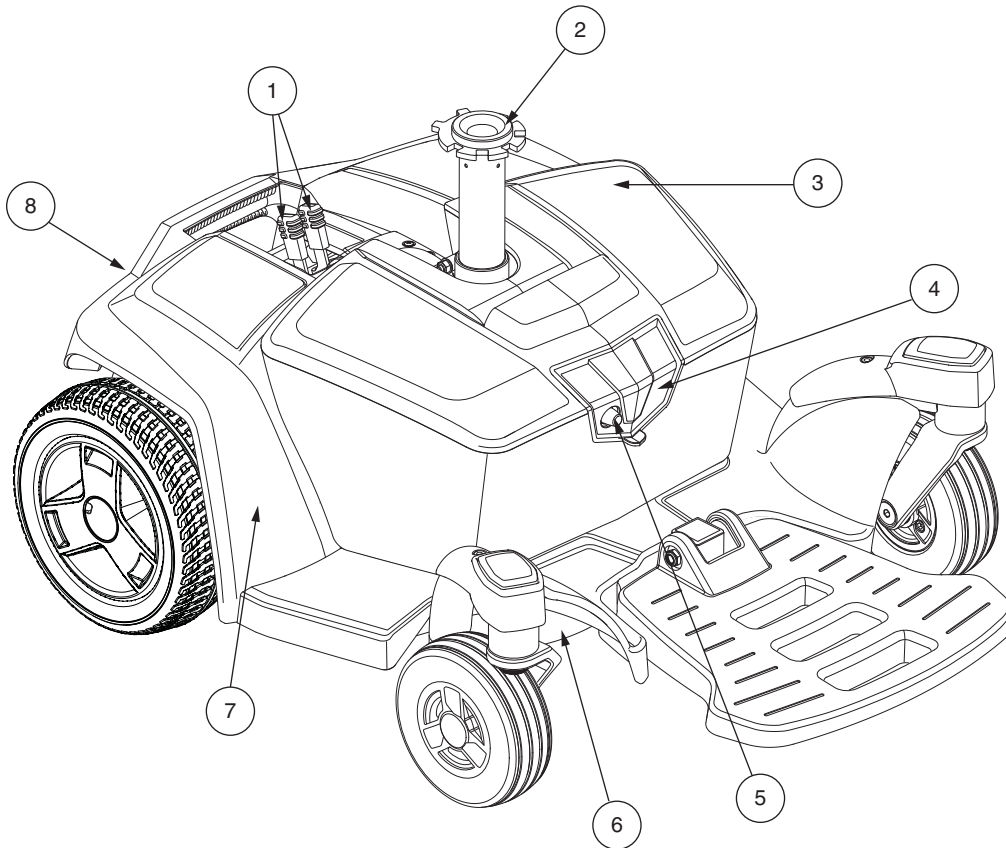

Figure 2. The Go-Chair Power Base

Electrical Components

The electrical components are located on the power base. The main circuit breaker is located on the front of the battery box. The controller connector is located on the back of the power base. **See figure 2.**

Controller Connector: This is where the controller connects to the power base. Each controller uses a different type of cable. Regardless of which type of controller is used, the cable must be secured to the assembly and not allowed to drag on the floor.

Battery Box Charger Port: This enables you to charge the batteries when the battery box is removed from the power base. See “Batteries and Charging.”

Main Circuit Breaker: The main circuit breaker is a safety feature built into your Go-Chair. When the batteries and the motors are heavily strained (e.g., from excessive loads), the main circuit breaker trips to prevent damage to the motors and the electronics. If the circuit trips, allow your Go-Chair to “rest” for approximately one minute. Next, push in the circuit breaker button, turn on the controller, and continue normal operation. If the main circuit breaker continues to trip repeatedly, contact an authorized Pride Provider.

Manual Freewheel Levers

For your convenience, your Go-Chair has a manual freewheel lever on each motor. Manual freewheel levers enable you to disable the drive system in order to maneuver the chair manually.



WARNING! Do not use the travel chair while the drive motors are disengaged! Do not disengage the drive motors when the travel chair is on an incline or decline, as the unit could roll on its own! Only engage the freewheel mode when on a level surface.



WARNING! It is important to remember that when your Go-Chair is in freewheel mode, the braking system is disengaged.

NOTE: Pride strongly recommends you do not charge your batteries while in freewheel mode.

NOTE: You must turn off the power before disabling the drive systems; otherwise, you may get an error code on the controller. To clear this code, turn off the controller and place the Go-Chair in drive mode. Then turn on the controller. The error message should be cleared. If not, contact an authorized Pride Provider.

To engage or disengage the drive system:

1. Locate the levers on the rear section of the power base. **See figure 3.**
2. Push the two levers toward the front of the power chair to engage the drive motors (drive mode).
3. Pull the two levers toward the rear of the power chair to disengage the drive motors (freewheel mode).

If a lever is difficult to move in either direction, rock your travel chair back and forth slightly. The lever should then move to the desired position.



WARNING! Do not use the freewheel lever handles as tie-down points to secure this product.

Anti-Tip Wheels

The anti-tip wheels are an integral and important safety feature of your Go-Chair. They are bolted to the frame at the rear of the chair. **See figure 3.**



PROHIBITED! Do not remove the anti-tip wheels or modify your travel chair in any way that is not authorized by Pride.

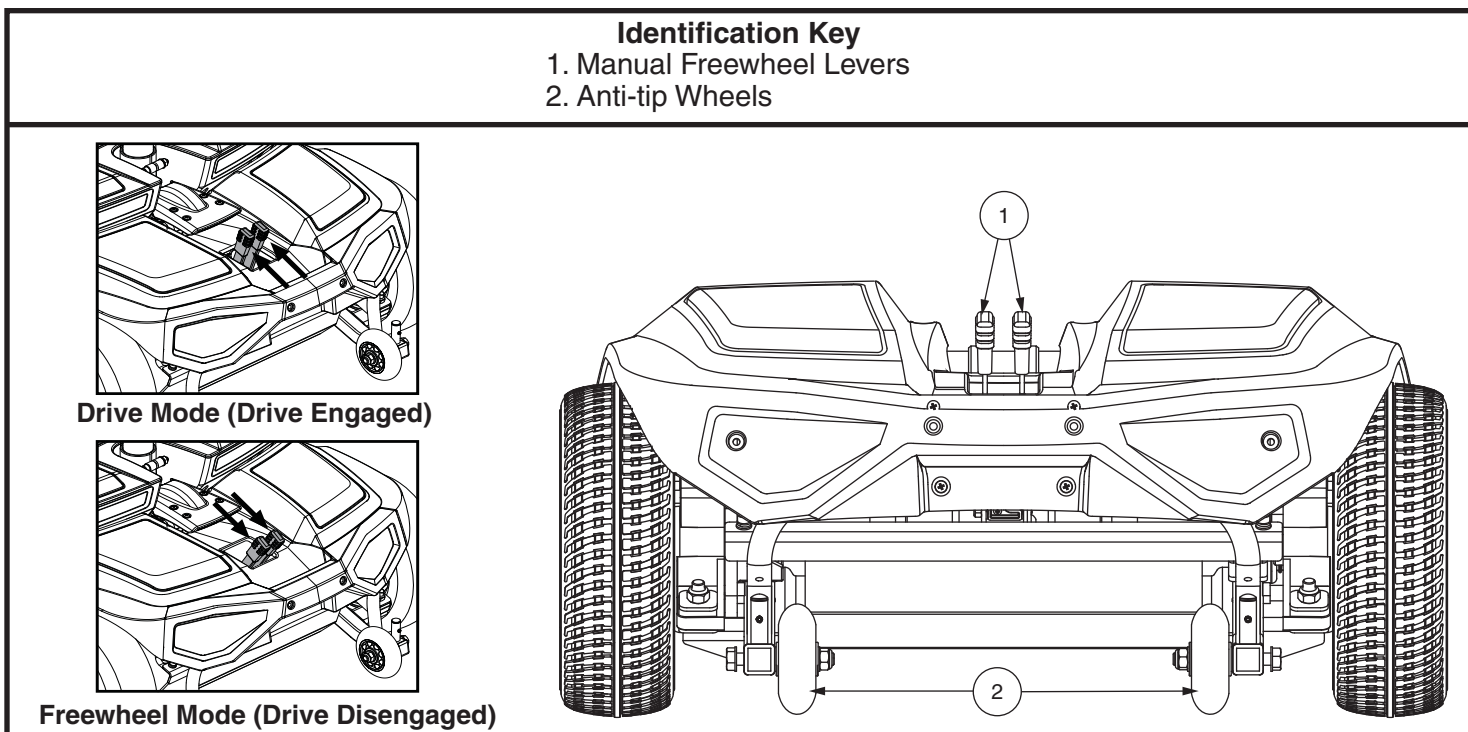

Figure 3. Back of Power Base

Initial Assembly

Your Go-Chair may require some assembly either before initial use or after transportation. It may also require disassembly to make some comfort adjustments. **Figure 4** details those parts of the Go-Chair that are designed to be disassembled and assembled by an end user or by a qualified caregiver before using the product or making comfort adjustments. There are two hex keys provided for use with controller installation and adjustment and foot platform adjustment.

NOTE: Any nylon insert lock nut removed during the disassembly or adjustment of the travel chair must be replaced with a new nut. Nylon insert lock nuts should not be reused as it may cause damage to the nylon insert, resulting in a less secure fit. Replacement nylon insert lock nuts are available at local hardware stores or through your authorized Pride Provider.

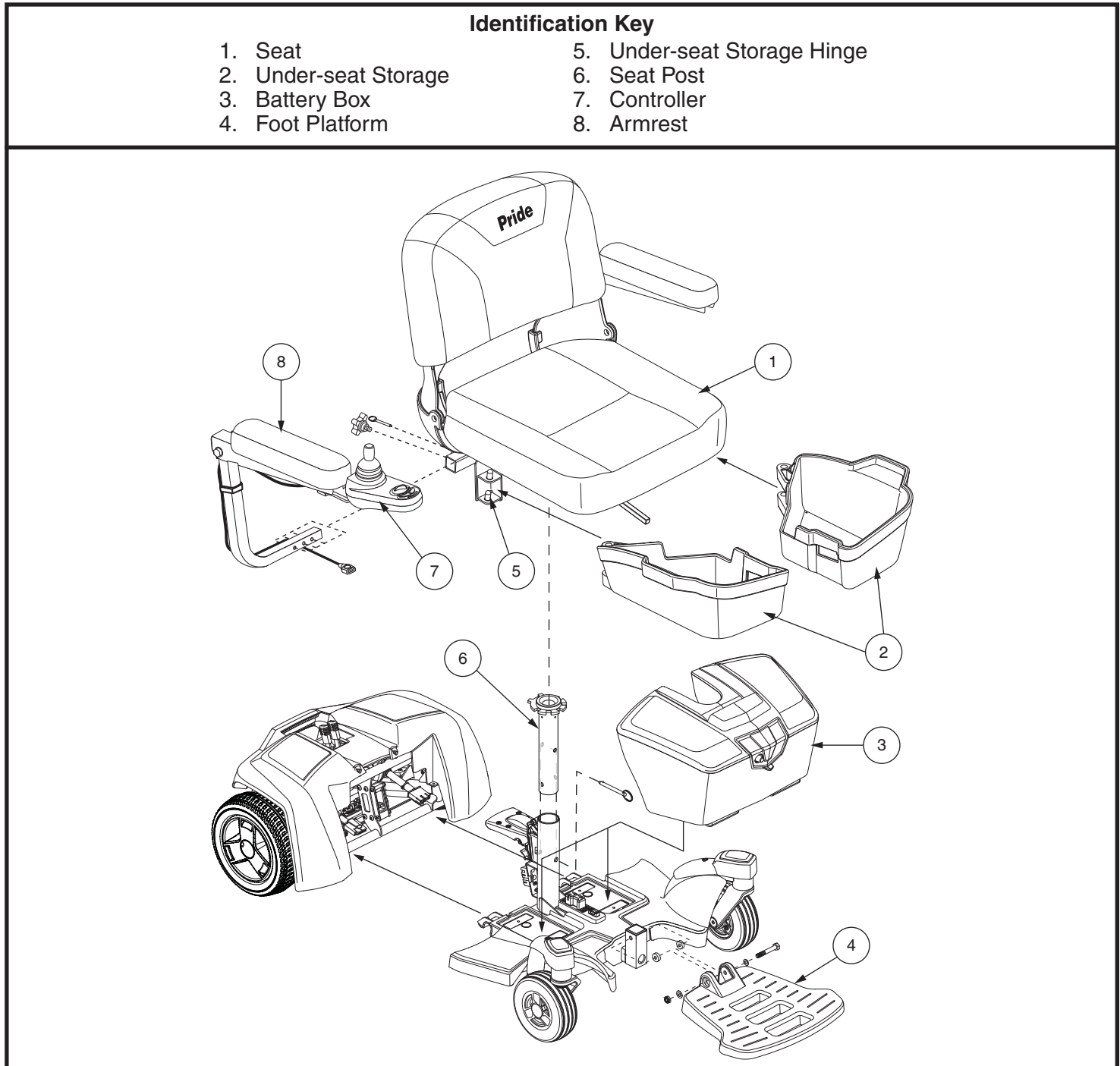

Figure 4. Go-Chair Assembly View

Seat Installation

It may be necessary to install the seat either prior to initial operation or after transporting your Go-Chair. The seat is attached to the power base by a height-adjustable seat post.



WARNING! Do not pick up the seat frame by the armrests. They are free to pivot, and you may lose control of the seat if they do so.

To install the seat:

1. Adjust the seat height if necessary. See “Comfort Adjustments.”
2. Set the seat onto the seat post. **See figure 5.**
3. Install under-seat storage. See “Comfort Adjustments.”
4. Install the controller into the armrest, and tighten the setscrew under the armrest.
5. Route the controller harness to the rear of the power base.
6. Plug the controller harness connector into the power base.
7. Secure the controller harness to the armrest with wire ties. **See figure 5.**

MANDATORY! Prevent controller harness damage! Avoid routing the controller harness on the outside of the armrest pad. Route the harness under the armrest or toward the inside of the armrest pad. Use correct tie-down points for the controller harness to prevent the harness from getting caught in the drive tires, pinched in the seat frame, or damaged when passing through doorways.



Disassembly

The Go-Chair disassembles into five components: the seat, the under-seat storage bin, the battery box, the rear section of the power base, and the front section of the power base. **See figure 6.**

To disassemble the Go-Chair:

1. Turn off the power to the controller.
2. Place the Go-Chair in drive mode, if not in drive mode already. See “Your Go-Chair.”
3. Unplug the controller from power base.
4. Remove under-seat storage. See “Comfort Adjustments.”
5. Remove the seat by lifting it straight up and off of the Go-Chair. If you encounter resistance when removing the seat, disengage the seat release lever and swivel the seat back and forth while lifting up on the seat.
6. Grasp the battery box handle and lift up to disengage the box from the power base, then tilt the box forward slightly and pull it away from the power base.
7. Disconnect two halves using the frame release lever.

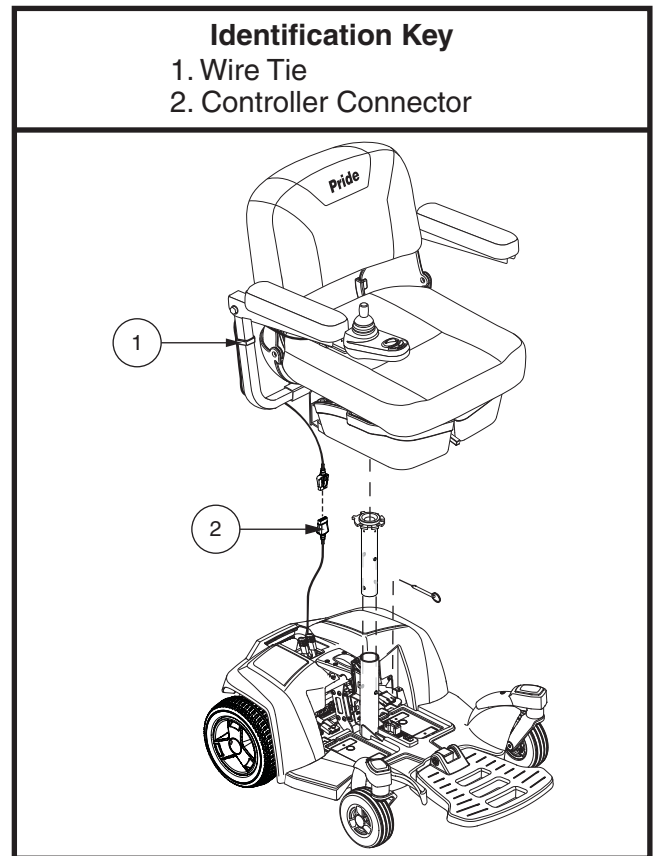

Figure 5. Seat Installation

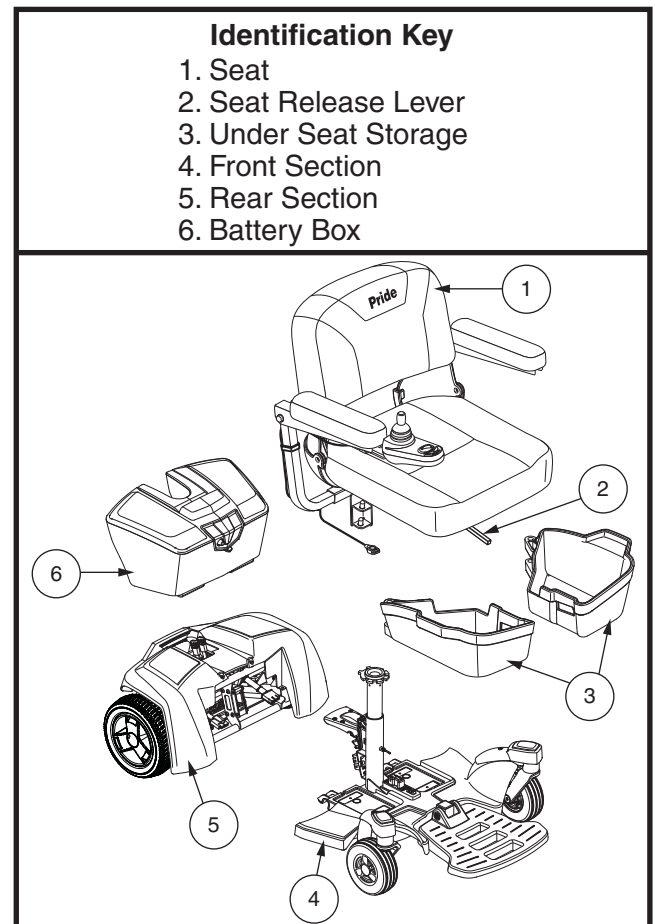

Figure 6. Go-Chair Components

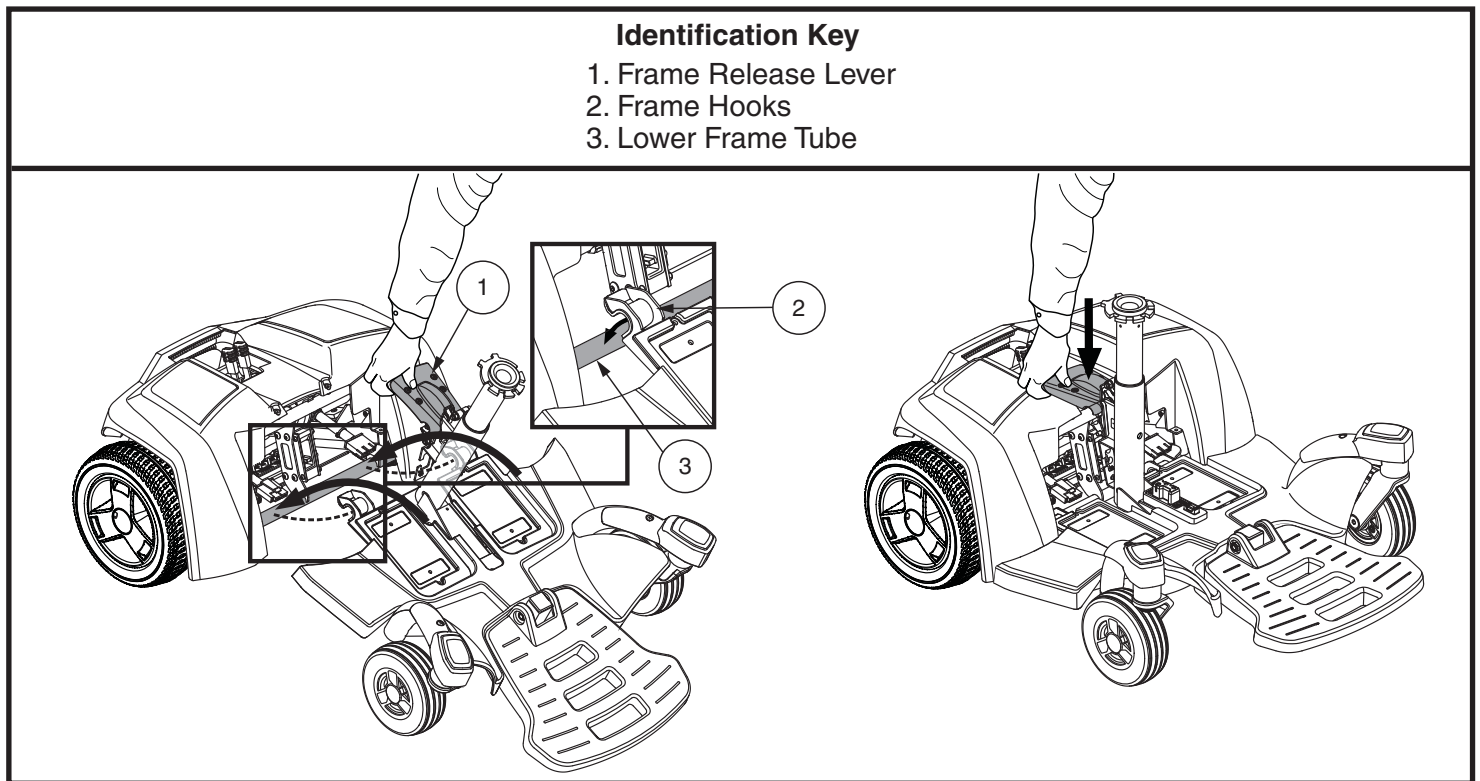

Figure 7. Go-Chair Assembly

Assembly

1. Use the frame release lever to lift the front section as you align the frame hooks of the front section with the lower frame tube of the rear section. **See figure 7.**
2. Once the frame hooks are over the lower frame tube, lower the front section and pivot the rear section simultaneously. This will engage the frame lock-up automatically. **See figure 7.**
3. Reinstall the battery pack
4. Reinstall the seat and rotate it until it is secured into place.
5. Plug the controller into the power base.
6. Reinstall under-seat storage.

Comfort Adjustments

After becoming familiar with your travel chair's operation, you may find the need to make some adjustments to increase your comfort, such as seat height, armrest width, foot platform depth, and controller position. Use the steps below to make comfort adjustments.

WARNING! The center of gravity of your travel chair was factory set to a position that meets the needs of the demographic majority of users. Your authorized Pride Provider has evaluated your travel chair and made any necessary adjustments to suit your specific requirements. Do not change your seating configuration without first contacting Pride Mobility Products or your authorized Pride Provider.



WARNING! Some travel chair components are heavy. You may need assistance to lift or carry them. Please refer to the specification table for specific component weights before you disassemble the travel chair.

WARNING! Remove the occupant from the Go-Chair before making any adjustments.

You may need the following to make comfort adjustments:

- metric/standard socket set and ratchet
- adjustable wrench
- metric/standard hex key set
- thread lock

Seat Height Adjustment

You can adjust the seat to two different heights in 1 in. (2.5-cm) increments. Seat height adjustment requires the removal of the battery box.

To change the seat height:

1. Turn off the power to the controller.
2. Ensure the travel chair is in drive mode. **See figure 3.**
3. Disconnect the controller connector from the power base. **See figure 5.**
4. Remove under-seat storage.
5. Disengage the seat release lever.
6. Swivel the seat left or right and then pull it up and off of the power base.
7. Remove the battery box.
8. Loosen the hardware at the rear of the seat post. **See figure 8**
9. Pull seat post pin for height adjustment. **See figure 8.**
10. Raise or lower the upper seat post to the desired position.
11. Reinstall seat post pin.
12. Tighten the hardware at the rear of the seat post.
13. Reinstall the battery box.
14. Reinstall the seat.
15. Reinstall under-seat storage.
16. Reconnect the controller to the power base.

NOTE: To rotate the seat, use the seat release lever located under the front of the seat.

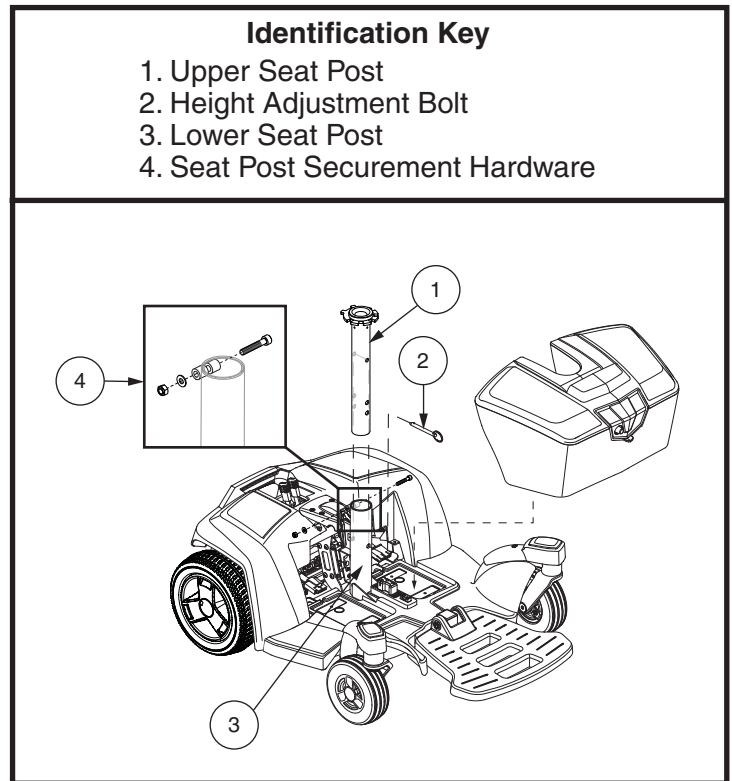

Figure 8. Seat Height Adjustment

Armrest Width Adjustment

You can change each armrest's width independently of the other.

NOTE: *Changing the armrest width may increase the overall width of your Go-Chair.*

To change the armrest width:

1. Locate the two armrest knobs on each side of the seat frame. **See figure 9.**
2. Loosen the knobs and remove detent pin.
3. Slide the armrests in or out to the desired width.
4. Tighten the knobs and reinsert detent pin.

Foot Platform Angle Adjustment

You can adjust the angle of the foot platform. **See figure 10.**

To adjust the foot platform angle:

1. Flip up the foot platform and locate the adjustment screw.
2. Turn the adjustment screw to raise or lower the front of the foot platform. **See figure 10.**

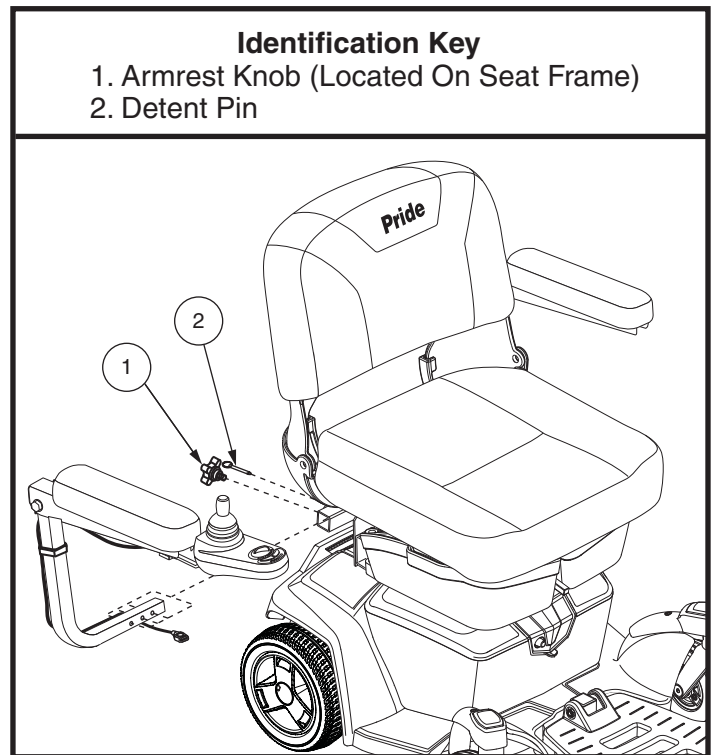

Figure 9. Armrest Width Adjustment

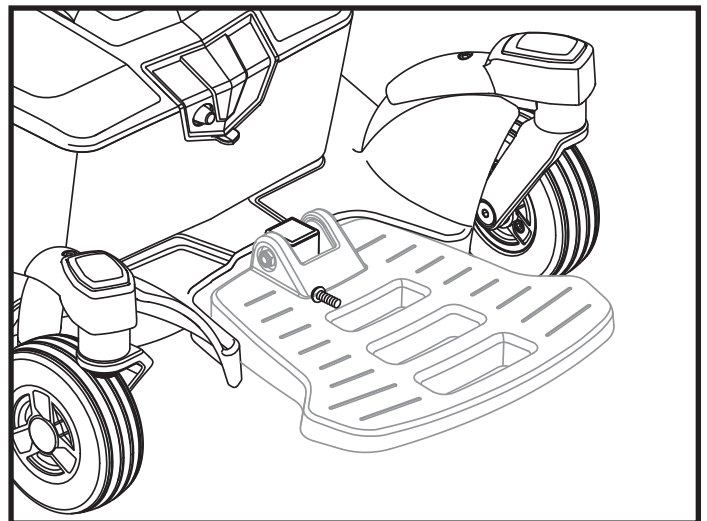

Figure 10. Foot Platform Angle Adjustment

Controller Position

You can position the controller for either left-hand or right-hand use.



WARNING! Do not place the controller harness so that it can be pinched in the seat frame or the power base frame.

To change the controller position:

1. Turn off the power to the controller.
2. Cut the wire tie(s) securing the controller harness to the armrest.
3. Flip up the armrest and loosen the setscrew. **See figure 11.**
4. Slide the controller out of the armrest.
5. Loosen the setscrew in the other armrest.
6. Place the controller in the other armrest.
7. Tighten the setscrew to secure the controller.
8. Use a wire tie to secure the controller harness to the armrest, ensuring the armrest can freely be raised and lowered without any tension on the harness so they do not become disconnected.
9. Plug the controller connector into the power base.

Under-seat Storage

To operate under-seat storage

1. Lift up slightly on the latch on the side of the under-seat storage bin (**See figure 12**) and swing the under-seat storage bin out and away from the travel chair.
2. To close the under-seat storage bin, push the under-seat storage bin toward the center of the travel chair until you hear the latch engage.



WARNING! Ensure both under-seat storage bins are latched prior to operating your travel chair.

To remove the under-seat storage

1. Lift up slightly on the latch on the side of the under-seat storage bin (**See figure 12**) and swing the under-seat storage bin out and away from the travel chair until it is fully open.
2. Lift the under-seat storage bin up and off the travel chair.

To install the under-seat storage

1. Align the slot on the under-seat storage bin over the securement post.
2. Lower the under-seat storage pin onto the securement post and push the under-seat storage bin toward the center of the travel chair until you hear the latch engage.

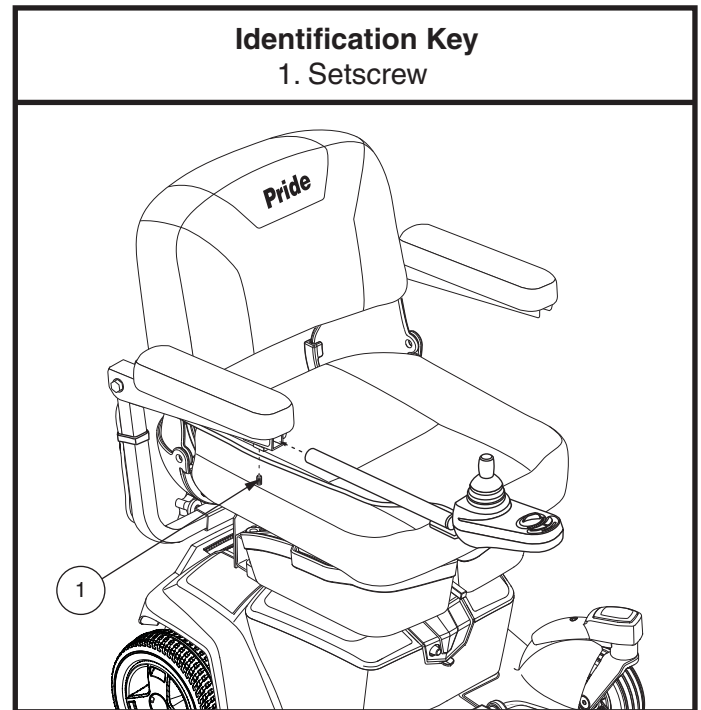

Figure 11. Controller Position

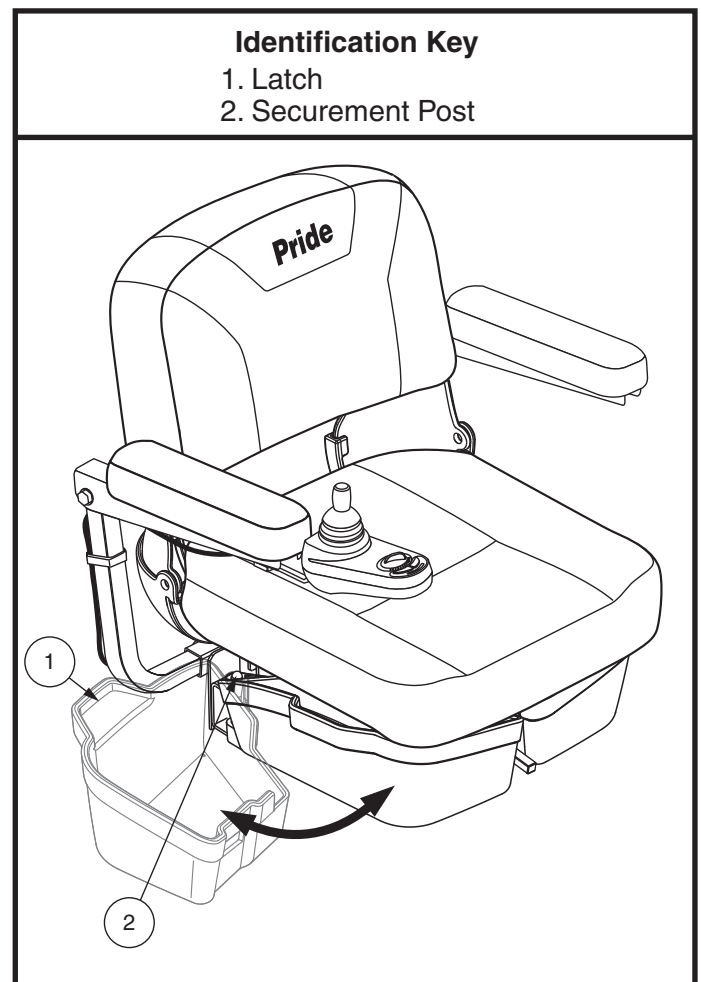

Figure 12. Under-seat Storage

Positioning Belt

Your Go-Chair may be equipped with a positioning belt that can be adjusted for operator comfort. **See figure 13.** The positioning belt is designed to support the operator so that he/she does not slide down or forward in the seat. The positioning belt is not designed for use as a restraining device.

WARNING! The positioning belt is not designed for use as a seat belt in a motor vehicle. Nor is your travel chair suitable for use as a seat in any vehicle. Anyone traveling in a vehicle should be properly belted into seats approved by the vehicle manufacturer.



WARNING! The positioning belt should be secured at all times. Never allow the positioning belt to hang or drag on the floor as it may become entangled.

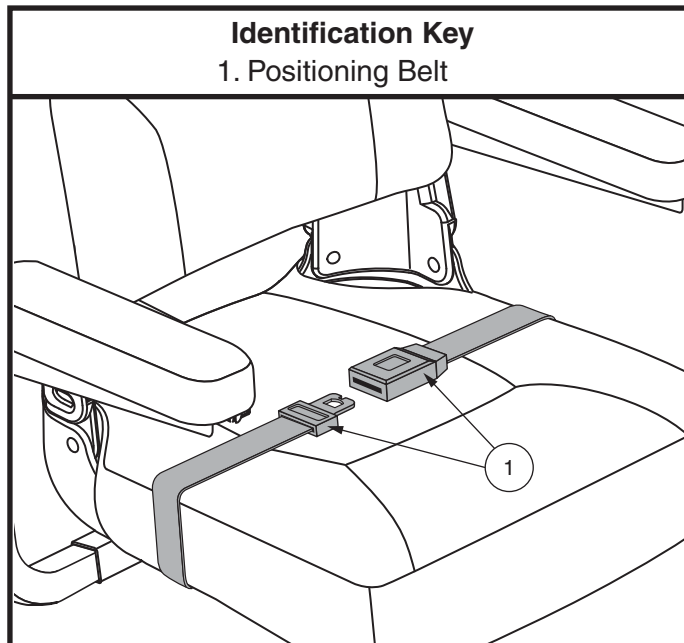

Figure 13. Positioning Belt Adjustment

To install the positioning belt:

1. Remove the rearmost screw that holds the under-seat storage (see figure 4)hinge to the seat base on both the left and right seat hinges.
2. Insert the screw through the supplied washer, through the positioning belt and into the seat base for each side of the travel chair seat.
3. Tighten both screws.

To adjust the positioning belt:

1. Once seated, insert the metal tab on one side of the belt into the plastic housing on the opposite side until you hear a click. **See figure 13.**
2. Pull the excess strap attached to the metal tab until it is secure, but not so tight as to cause discomfort.

To release the positioning belt:

1. Press the push button mechanism on the plastic housing.

MANDATORY! Make sure the positioning belt is properly secured to the travel chair and is adjusted for operator comfort before each use.



MANDATORY! Inspect the positioning belt for loose parts or damage, including tears, worn spots, bent hardware, damaged latch mechanisms, dirt or debris, before each use of the travel chair. If you discover a problem, contact your authorized Pride Provider.

Batteries and Charging

The Go-Chair uses two long-lasting, 12-volt, deep-cycle batteries. These batteries are sealed and maintenance free. Since they are sealed, there is no need to check the electrolyte (fluid) level. Deep-cycle batteries are designed to handle a longer and deeper discharge. Though they are similar in appearance to automotive batteries, they are not interchangeable. Automotive batteries are not designed to handle a long, deep discharge, and also are unsafe for use in travel chairs.



MANDATORY! Battery posts, terminals, and related accessories contain lead and lead compounds. Wear goggles and gloves when handling batteries and wash hands after handling.



PROHIBITED! Always use two batteries of the exact same type, chemistry, and amp-hour (Ah) capacity. Refer to the specifications table in this manual and in the manual supplied with the battery charger for recommended type and capacities.



WARNING! Contact your authorized Pride Provider if you have any questions regarding the batteries in your travel chair.

Charging the Batteries

The battery charger is essential in providing long life for your Go-Chair batteries. It is designed to optimize your travel chair's performance by charging the batteries safely, quickly, and easily. The battery charger is only functional when the charger power cord is plugged into an electrical outlet.



PROHIBITED! Removal of grounding prong can create electrical hazard. If necessary, properly install an approved 3-pronged adapter to an electrical outlet having 2-pronged plug access.



PROHIBITED! Never use an extension lead to plug in your battery charger. Plug the charger directly into a properly wired standard electrical outlet.



PROHIBITED! Do not allow unsupervised children to play near the Go-Chair while the batteries are charging. Pride recommends that you do not charge the batteries while the travel chair is occupied.



MANDATORY! Read the battery charging instructions in this manual and in the manual supplied with the battery charger before charging the batteries.



WARNING! Explosive gases may be generated while charging the batteries. Keep the Go-Chair and battery charger away from sources of ignition such as flames or sparks and provide adequate ventilation when charging the batteries.

WARNING! You must recharge your Go-Chair's batteries with the supplied off-board charger. Do not use an automotive-type battery charger.

WARNING! Inspect the battery charger, wiring, and connectors for damage before each use. Contact your authorized Pride Provider if damage is found.



WARNING! Do not attempt to open the battery charger case. If the battery charger does not appear to be working correctly, contact your authorized Pride Provider.

WARNING! Be aware that the battery charger case may become hot during charging. Avoid skin contact and do not place on surfaces that may be affected by the heat.

WARNING! If the battery charger is equipped with cooling slots, then do not attempt to insert objects through these slots.



WARNING! If your battery charger has not been tested and approved for outdoor use, then do not expose it to adverse or extreme weather conditions. If the battery charger is exposed to adverse or extreme weather conditions, then it must be allowed to adjust to the difference in environmental conditions before use indoors. Refer to the manual supplied with the battery charger for more information.

NOTE: The *Go-Chair* batteries can be charged with the battery box either installed on or removed from the power base.

To charge the batteries using the off-board charger:

1. Position the front of your travel chair next to a standard electrical outlet.
2. Be certain the controller power is turned off and the freewheel levers are in the engaged position. See “Your Go-Chair.”
3. Plug the off-board charger into the off-board charger/programming socket of the controller.
4. Plug the off-board charger into the electrical outlet.

WARNING! The LED lights on the charger indicate different charger conditions at various times: charger power on, charging in progress, and charging complete. If the LED does not indicate that charging is completed within 24 hours, unplug the charger from the outlet and contact your authorized Pride Provider. Refer to the manual supplied with the charger for a complete explanation of these indicators.

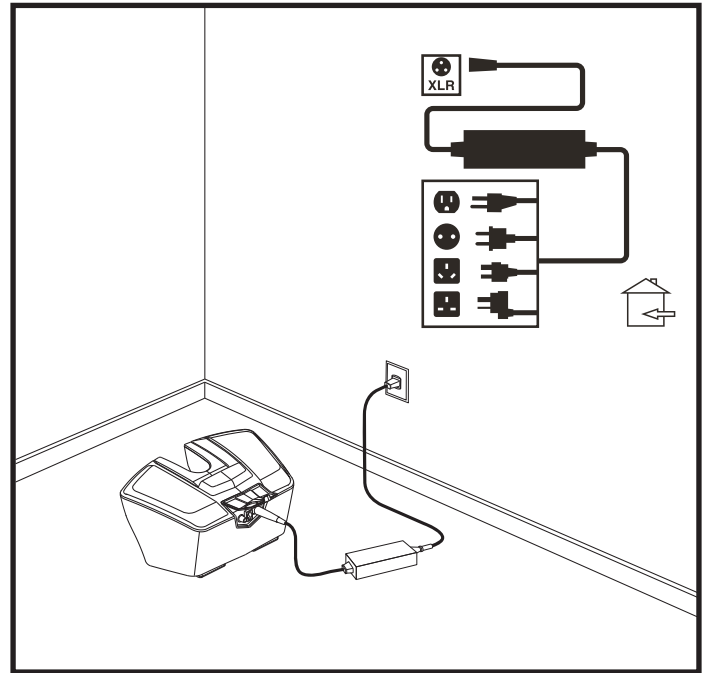

Figure 14. Battery Charging

5. When the batteries are fully charged, unplug the off-board charger from the electrical outlet and then from the controller.

To charge the batteries with the battery box removed from the power base:

1. Remove the battery box from the power base.
2. Position the battery box next to a standard electrical outlet.
3. Plug the off-board charger into the battery box charger port. **See figure 14.**
4. Plug the off-board charger into the electrical outlet.

NOTE: If this is a *Pride* off-board charger, then there are two lights in it. The red light indicates that power to the off-board charger is on. The green light indicates that the batteries are fully charged. If it is not a *Pride* off-board charger, then follow the instructions supplied by the manufacturer.

5. When the batteries are fully charged, unplug the off-board charger from the wall outlet and then from the battery box.
6. Reinstall the battery box to the power base.

NOTE: Turn off the power to the controller and remove the seat before removing the Go-Chair battery box.

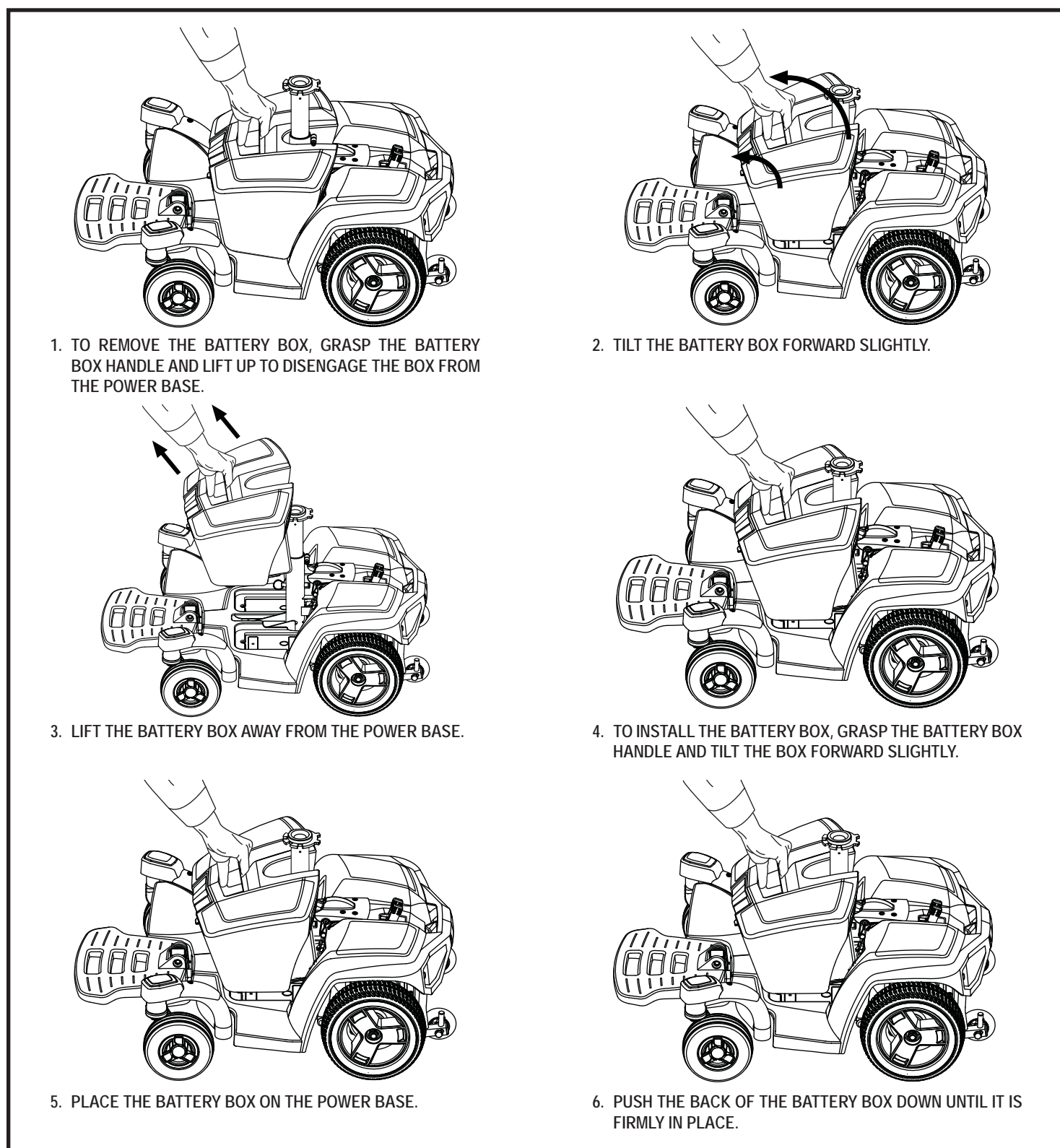

Figure 15. Removal and Installation of Go-Chair Battery Box

Battery Break-in

To break in new batteries for maximum efficiency:

1. Fully recharge any new battery prior to its initial use. This brings the battery up to 90% of its peak performance level.
2. Operate your Go-Chair throughout the house and yard. Move slowly at first, and do not travel too far until you become accustomed to the controls and break in the batteries.
3. Give the batteries another full charge of at least 8-14 hours and operate your Go-Chair again. The batteries will perform at over 90% of their potential.
4. After four or five charging cycles, the batteries will top off at 100% charge and last for an extended period.

Frequently Asked Questions (FAQs)

How does the charger work?

The battery charger takes the standard electrical outlet voltage (alternating current) and converts it to 24 VDC (direct current). The batteries use direct current to run your Go-Chair. When the battery voltage is low, the charger works harder to charge the battery. As the battery voltage approaches full charge, the charger does not work as hard to complete the charging cycle. When the battery is fully charged, the amperage from the charger is nearly at zero. This is how the charger maintains a charge but does not overcharge the battery.

Can I use a different battery charger?

You should use the charger supplied with the Go-Chair. It is the safest, most efficient tool to charge the batteries. We do not recommend using other types of chargers (e.g., an automotive battery charger).

NOTE: Your travel chair's charger will not operate after the batteries have been discharged to nearly zero capacity. If this happens, call an authorized Pride Provider for assistance.

How often must I charge the batteries?

Many factors come into play when deciding how often to charge the batteries. You may use your Go-Chair all day on a daily basis or you may not use it for weeks at a time.

■ Daily Use

If you use your Go-Chair on a daily basis, charge the batteries as soon as you are finished using your Go-Chair. Your Go-Chair will be ready each morning to give you a full day's service. It is recommended that you charge the batteries at least 8 to 14 hours after daily use. Pride recommends that you charge your batteries for an additional 4 hours after the battery charger indicates that charging is complete.

■ Infrequent Use

If you use your Go-Chair infrequently (once a week or less), you should charge the batteries at least once per week for 12 to 14 hours.

NOTE: Keep your batteries fully charged and avoid deeply discharging your batteries. Refer to the manual supplied with the battery charger for charging instructions. Pride recommends charging your batteries for at least 48 continuous hours once per month to improve battery performance and battery life.

How can I get maximum range or distance per charge?

Rarely do you have an ideal driving situation such as smooth, flat, hard terrain with no wind, hills, or curves. More often you are presented with hills, pavement cracks, uneven and loosely packed surfaces, curves, and wind. All of these factors will affect the distance or running time per battery charge. Below are a few suggestions for obtaining the maximum range per charge:

- Always charge the batteries fully prior to your trip.
- Plan your trip in advance to avoid inclines if possible.
- Limit baggage weight to essential items.
- Try to maintain an even speed and avoid stop-and-go driving.
- Pride recommends charging your batteries for at least 48 continuous hours once per month to improve battery performance and battery life.

What type of batteries should I use?

We recommend deep-cycle batteries that are sealed and maintenance free. AGM batteries are deep-cycle batteries that are similar in performance. Refer to the specifications table for more information regarding the batteries used with your Go-Chair.



WARNING! Corrosive chemicals contained in batteries. Use only AGM batteries to reduce the risk of leakage or explosive conditions.

Why do my new batteries seem weak?

Deep-cycle batteries employ a much different chemical technology than that used in car batteries, nickel-cadmium (nicads), or in other common battery types. Deep-cycle batteries are specifically designed to provide power, drain down their charge, and then accept a relatively quick recharge. AGM batteries should be charged as often as possible. They do not have a “memory” like nickel-cadmium batteries.

We work closely with our battery manufacturer to provide a battery that best suits your Go-Chair’s specific demands. Fresh batteries arrive regularly at Pride and are promptly shipped with a full charge. During shipping, the batteries encounter temperature extremes that may influence initial performance. Heat robs the charge from the battery, and cold slows the power available and extends the time needed to recharge the battery (just as with a car battery).

It might take a few days for the temperature of the battery to stabilize and adjust to its new ambient temperature. More importantly, it will take a few “charging cycles” (a partial drain—then a full recharge) to establish the critical chemical balance that is essential to the battery’s peak performance and long life. It will be well worth it to take the time to break in your battery properly.

How can I ensure maximum battery life?

A fully charged deep-cycle battery will provide reliable performance and extended battery life. Keep your Go-Chair’s batteries fully charged whenever possible. Batteries that are regularly and deeply discharged, infrequently charged, or stored without a full charge may be permanently damaged, causing unreliable Go-Chair operation and limited battery life.

NOTE: The useful life of a battery is quite often a reflection of the care it receives.

How should I store my Go-Chair and its batteries?

If you do not use your Go-Chair regularly, we recommend maintaining battery vitality by charging the batteries at least once per week.

If you do not plan on using your Go-Chair for an extended period, fully charge the batteries prior to storage. Disconnect the battery harnesses and store the Go-Chair in a warm, dry environment. Avoid temperature extremes, such as freezing and excessively hot conditions, and never attempt to charge a frozen battery. A cold or frozen battery should be warmed for several days prior to recharging.

What about public transportation?

AGM and Gel-Cell batteries are designed for application in travel chairs and other mobility vehicles. These batteries are Federal Aviation Administration (FAA) approved, allowing safe transportation on aircraft, buses, and trains, as there is no danger of spillage or leakage. We suggest you contact the carrier's ticket counter in advance to determine that carrier's specific requirements.

What about shipping?

If you wish to use a freight company to ship your Go-Chair to your final destination, repack your Go-Chair in the original shipping container if possible and ship the batteries in separate boxes.

Care and Maintenance

Your Go-Chair is a sophisticated travel mobility vehicle. Like any motorized vehicle, it requires routine maintenance checks. You can perform some of these checks, but others require assistance from an authorized Pride Provider. Preventive maintenance is very important. If you follow the maintenance checks in this section as scheduled, you can help ensure that your Go-Chair gives you years of trouble-free operation. If you have any doubt as to your Go-Chair's care or operation, contact an authorized Pride Provider.



WARNING! Do not service the Go-Chair when the seat is occupied.

Your Go-Chair, like most electrical equipment, is susceptible to damage from the elements. Avoid damp areas of any kind.



WARNING! Direct or prolonged exposure to water or dampness could cause the Go-Chair to malfunction electronically and mechanically. Water can cause electrical components to corrode and the chair's frame to rust. Travel chairs should be examined periodically for signs of corrosion caused by water exposure, bodily fluid exposure, or incontinence. Damaged components should be replaced or treated immediately.

Should your Go-Chair come in contact with water:

1. Dry your Go-Chair as thoroughly as possible with a towel.
2. Allow your Go-Chair to sit in a warm, dry place for 12 hours to allow unseen water to evaporate.
3. Check the controller operation and the brakes before using your Go-Chair again.
4. If any inconsistencies are found, take your Go-Chair to an authorized Pride Provider. Travel chairs that are frequently exposed to sources of water, such as incontinence, should be inspected often for corrosion and electronic components may need to be replaced frequently.

Temperature

- Some of the parts of your Go-Chair are susceptible to extreme changes in temperature. Always keep your Go-Chair between the temperatures of 18°F (-8°C) and 122°F (50°C).
- In extremely cold temperatures the batteries may freeze. The specific temperature at which they freeze depends on a number of factors, such as battery charge, usage, and composition of the batteries (e.g., AGM).

General Guidelines

- Avoid knocking or bumping the controller.
- Avoid prolonged exposure of your Go-Chair to extreme conditions, such as heat, cold, or moisture.
- Keep the controller clean.
- Check all connectors to ensure that they are all tight and secured properly.
- If your travel chair is equipped, make sure pneumatic tires are inflated to the psi/bar/kPa air pressure rating indicated on each tire.



WARNING! Make sure pneumatic tires are inflated to the psi/bar/kPa air pressure rating indicated on each tire. Do not underinflate or overinflate your tires. Low pressure may result in loss of control, and overinflated tires may burst. Overinflating tires can cause them to explode.

WARNING! Do not use a high pressure hose to inflate your tires.

- Use a rubber conditioner on the tire sidewalls to help preserve them.



WARNING! Never use a rubber conditioner on the tread areas of the tires; doing so may make the tires slippery and cause your travel chair to skid.

- All wheel bearings are prelubricated and sealed. They require no subsequent lubrication.
- The body shroud has been sprayed with a clear sealant coating. You can apply a light coat of car wax to help it retain its high-gloss appearance.
- Check all electrical connections. Make sure they are tight and are not corroded. Batteries must sit flat within the battery tray, with the battery terminals facing inward, toward each other. Refer to the battery wiring lable for the correct wiring layout.



WARNING! Even though the Go-Chair has passed the necessary testing requirements for ingress of liquids, you should keep electrical connections away from sources of dampness, including direct exposure to water or bodily fluids and incontinence. Check electrical components frequently for signs of corrosion and replace as necessary.

Daily Checks

- With the controller turned off, check the joystick. Make sure it is not bent or damaged and that it returns to the neutral position when you release it. Check the rubber boot around the base of the controller for damage. Visually inspect the boot. Do not handle or try to repair it. See an authorized Pride Provider if there is a problem.
- Visually inspect the controller harness. Make sure that it is not frayed, cut, or has any wires exposed. See an authorized Pride Provider if there is a problem.
- Check for flat spots on solid tires. Flat spots could adversely affect stability.
- Inspect the seating system, armrests and front riggings for loose hardware, stress points or damage. See your authorized Pride Provider if there is a problem.

Weekly Checks

- Disconnect and inspect the controller from the power base. Look for corrosion. Contact an authorized Pride Provider if necessary.
- Ensure that all parts of the controller system are securely fastened to your Go-Chair. Do not overtighten any screws.
- Check for proper tire inflation. If a tire does not hold air, contact your authorized Pride Provider for replacement of the tube.
- Check the brakes. This test should be carried out on a level surface with at least 3 feet (1 meter) of clearance around your Go-Chair.

To check the brakes:

1. Turn on the controller and turn down the speed level on your Go-Chair.
2. After one second, check the battery condition meter. Make sure that it remains on.
3. Slowly push the controller forward until you hear the electric brakes click. Immediately release the controller. You must be able to hear each electrical brake operating within a few seconds of controller movement. Repeat this test three times, pushing the controller rearwards, then left, and then right.

Monthly Checks

- Check for drive tire wear. See an authorized Pride Provider for repair.
- Check the caster wheels for wear. Replace them as necessary.
- Check the caster forks for damage or fluttering which indicates that they may need to be adjusted or have the bearings replaced. See an authorized Pride Provider for repair.
- Check the entire travel chair for loose hardware and changes in the function or performance of the travel chair. See your authorized Pride Provider for service and repair.
- Keep your Go-Chair clean and free of foreign material, such as mud, dirt, hair, food, drink, etc.
-

Yearly Checks

Take your Go-Chair to an authorized Pride Provider for yearly maintenance, especially if you use your chair on a daily basis. This helps ensure that your Go-Chair is functioning properly and helps prevent future complications.

Storage

Your Go-Chair should be stored in a dry place, free from temperature extremes. When storing, disconnect the batteries from the Go-Chair. See “Batteries and Charging.”



WARNING! If you fail to store the unit properly, the frame can rust and the electronics can be damaged.

Batteries that are regularly and deeply discharged, infrequently charged, stored in extreme temperatures, or stored without a full charge may be permanently damaged, causing unreliable performance and limited service life. It is recommended that you charge the batteries periodically throughout periods of prolonged storage to ensure proper performance.

You may wish to place several boards under the frame of your Go-Chair to raise it off of the ground during periods of prolonged storage. This takes the weight off the tires and reduces the possibility of flat spots developing on the areas of the tires contacting the ground.

Disposal of Your Go-Chair

Your Go-Chair must be disposed of according to applicable local and national statutory regulations. Contact your local waste disposal agency or authorized Pride Provider for information on proper disposal of travel chair packaging, metal frame components, plastic components, electronics, batteries, neoprene, silicone, and polyurethane materials.

Cleaning and Disinfection

- Use a damp cloth and mild, non-abrasive cleanser to clean the plastic and metal parts of your Go-Chair. Avoid using products that may scratch the surface of your chair.
- If necessary, clean your product with an approved disinfectant. Make sure the disinfectant is safe for use on your product before application.

WARNING! Follow all safety instructions for the proper use of the disinfectant and/or cleaning agent before applying it to your product. Failure to comply may result in skin irritation or premature deterioration of upholstery and/or travel chair finishes.



WARNING! Never hose off your travel chair or place it in direct contact with water. Your travel chair has a painted, ABS plastic body shroud that allows it to be easily wiped clean with a damp cloth.

WARNING! Never use any chemicals to clean a vinyl seat, as they may cause the seat to become slippery or dry out and crack. Use soapy water and dry the seat thoroughly.

Wheel Replacement

If your chair is equipped with a solid tire insert, then you must replace the whole wheel assembly. Replacement wheel assemblies are readily available through an authorized Pride Provider.

WARNING! The wheels on your travel chair should only be serviced by an authorized Pride Provider or a qualified technician.



WARNING! Be sure that the power to the controller is turned off and the travel chair is not in freewheel mode before performing this procedure.

WARNING! When changing the tire, remove only the center lug nut and washer, then remove the wheel. If any further disassembly is required, deflate the tire completely or it may explode.

To change the wheel:

1. Turn off the power to the controller.
2. Set the Go-Chair up on blocks.
3. Remove the drive wheel nut and washer from the axle. **See figure 16.**
4. Pull the wheel off the axle.
5. Slide the new wheel back onto the shaft. Make sure that the key is in the axle slot.



WARNING! Ensure that the axle key is properly installed into the axle slot when mounting the wheel. If not installed securely, the braking and drive systems are disengaged which may cause personal injury or product damage.

6. Reinstall the drive wheel nut and washer onto the axle and tighten.



WARNING! Make sure both the nut and washer are reinstalled and tightened properly.

7. Remove the Go-Chair from the blocks.

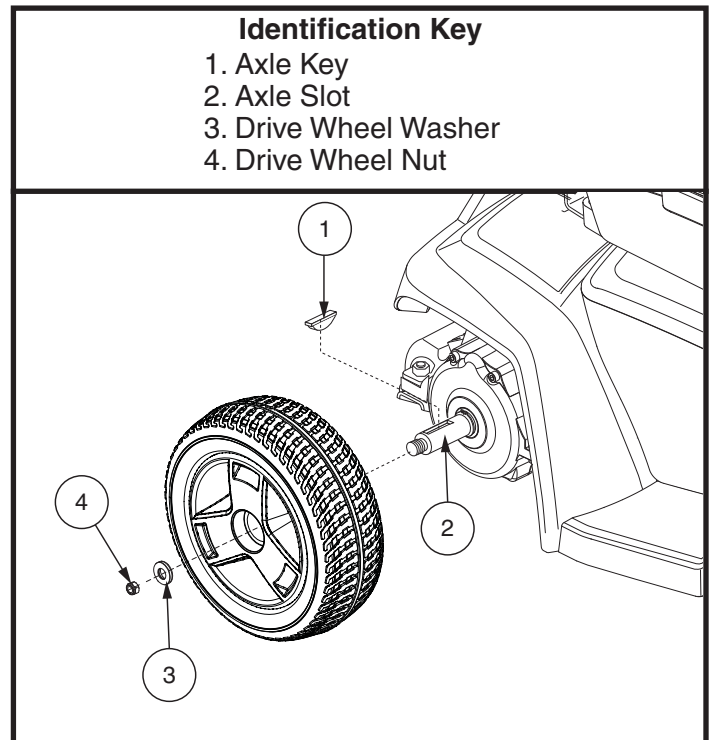

Figure 16. Go-Chair Drive Wheel

Battery Replacement

A battery wiring diagram is printed on a decal located inside the battery box. See the specifications table for correct battery specifications.



MANDATORY! Battery posts, terminals, and related accessories contain lead and lead compounds. Wear goggles and gloves when handling batteries and wash hands after handling.

WARNING! The batteries in your travel chair should only be serviced or replaced by an authorized Pride Provider or a qualified technician.

WARNING! Do not replace the batteries when the seat is occupied.



WARNING! Travel chair batteries are heavy. See specifications table. If you are unable to lift that much weight, be sure to get help. Use proper lifting techniques and avoid lifting beyond your capacity.

WARNING! Do not mix old and new batteries. Always replace both batteries at the same time.



PROHIBITED! Keep tools and other metal objects away from the battery terminals. Contact with tools can cause electrical shock.

You may need the following to change your batteries:

- metric/standard socket set and ratchet
- adjustable wrench
- screwdriver

To replace the batteries:

1. Remove the battery box from the Go-Chair.
2. Turn the pack upside down.
3. Remove all screws that hold the battery box halves together. **See figure 17.**
4. Flip the battery box back over so the handle is up and remove the lid.
5. Remove the red (+) positive and black (-) negative battery cables from each battery.
6. Unfasten the hook and loop straps from both batteries.
7. Remove the batteries.
8. Put the new batteries back into the battery box (battery terminals up and facing toward the center of the powerchair).
9. Fasten the hook and loop straps around both batteries.
10. Reconnect the two (2) battery cables to the battery terminals. Make sure the red cable is connected to the positive (+) terminal and the black cable is connected to the negative (-) terminal.
11. Replace the lid and carefully flip the battery box over so the handle is down.
12. Replace and tighten all the screws that hold the battery box together.
13. Reinstall the battery box back onto the Go-Chair.

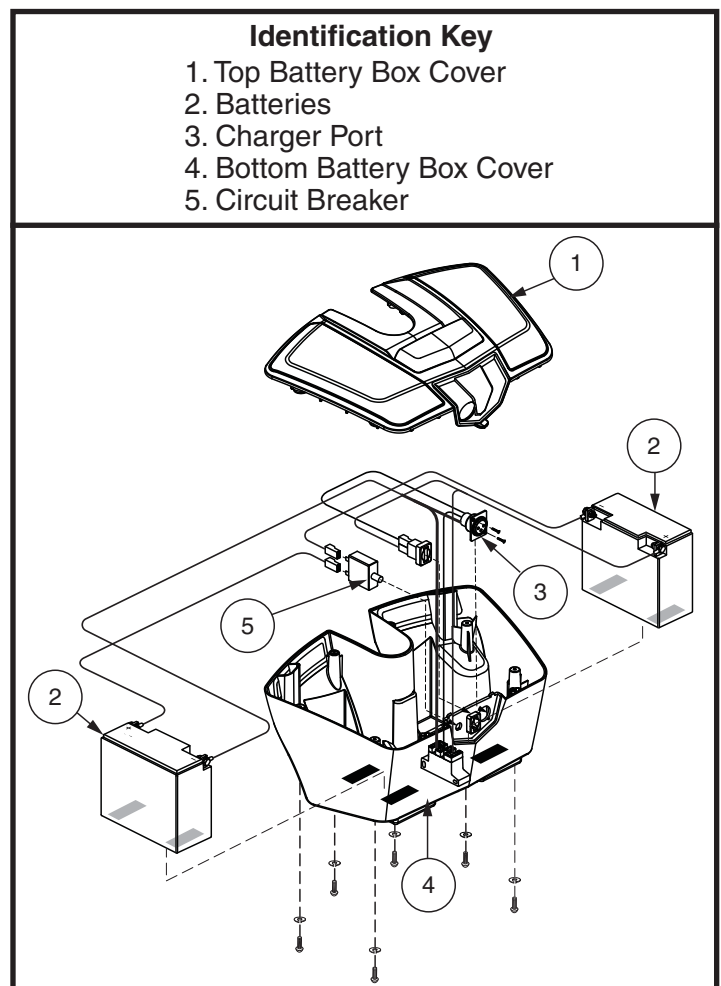

Figure 17. Go-Chair Battery Box

When to See An Authorized Pride Provider for Service

The following symptoms could indicate a serious problem with your Go-Chair. If necessary, contact an authorized Pride Provider. When calling, have the model number, serial number, nature of the problem, and the error code if available.

- Motor noise
- Frayed harnesses
- Cracked or broken connectors
- Uneven wear on any of the tires
- Jerky motion
- Pulling to one side
- Bent or broken wheel assemblies
- Does not power up
- Powers up, but does not move
- Loose seat or seating components

Corrective Maintenance

If the battery condition meter does not light up when you turn on the power:

- Check the harness connections. Make sure they are tight.
- Check the circuit breaker. Reset it if necessary.
- Check the battery connections.

If the above conditions prove normal, you can load test the batteries with a battery load tester. These testers are available at automotive parts stores. Disconnect both batteries before load testing and follow the directions that come with the load tester. If either one of the batteries fails the load test, replace both of them. If your Go-Chair still does not power up, contact an authorized Pride Provider.

USA

182 Susquehanna Avenue
Exeter, PA 18643-2694

Canada

5096 South Service Road
Beamsville, Ontario L0R 1B3

UK

32 Wedgwood Road
Bicester, Oxfordshire OX26 4UL
www.pridemobility.co.uk

Australia

20-24 Apollo Drive
Hallam, Victoria 3803
www.pridemobility.com.au

New Zealand

38 Lansford Crescent
Avondale
Auckland, New Zealand 1007
www.pridemobility.co.nz

Italy

Via del Progresso, ang. Via del Lavoro
Loc. Prato della Corte
00065 Fiano Romano (RM)
www.pride-italia.it

B.V.

Castricummer Werf 26
1901 RW Castricum
The Netherlands
www.pride-mobility.nl

www.pridemobility.com

Product Serial #

